

MODEL 24A STANDARD

SERIAL No. _____

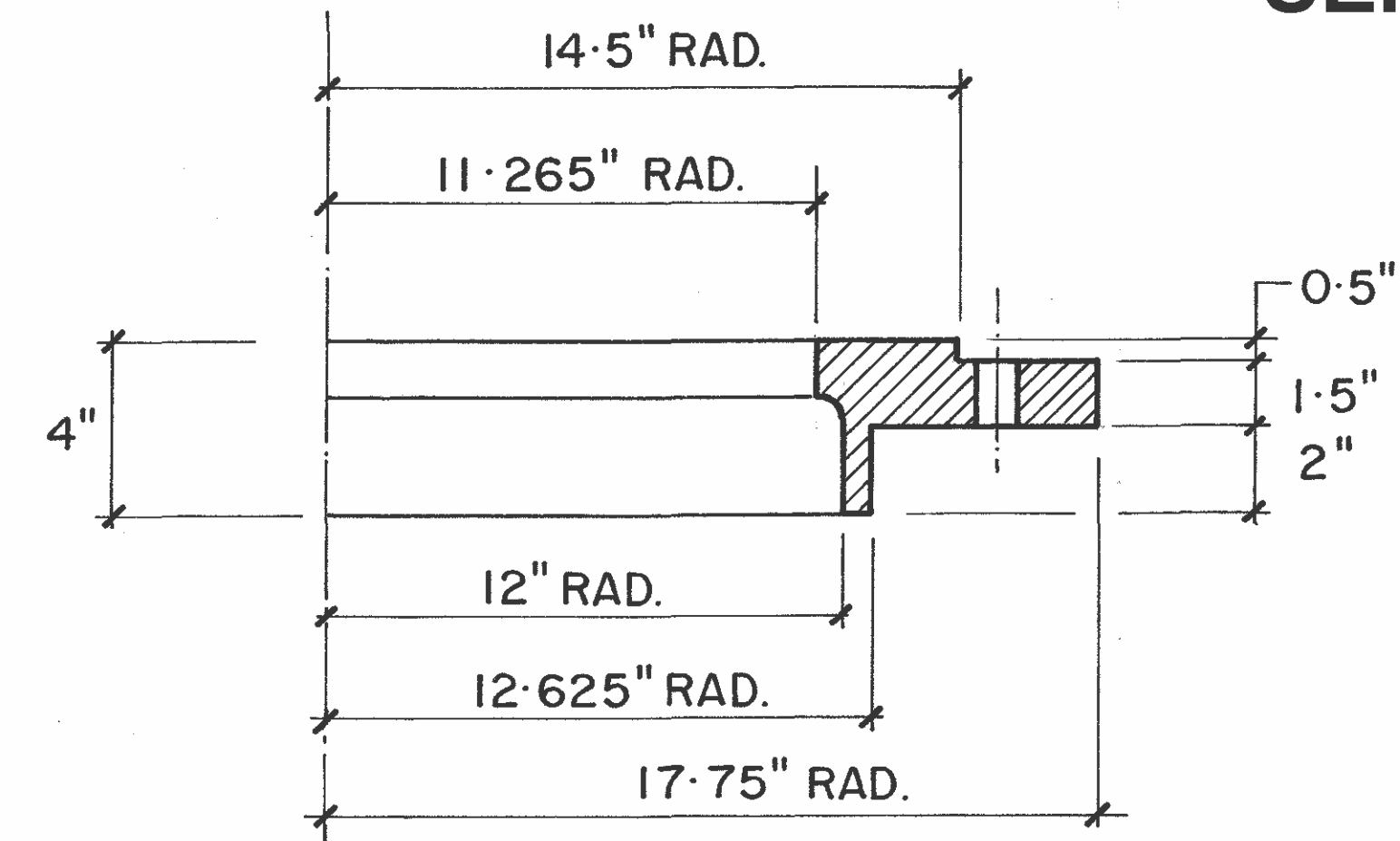

BASE RING DETAIL

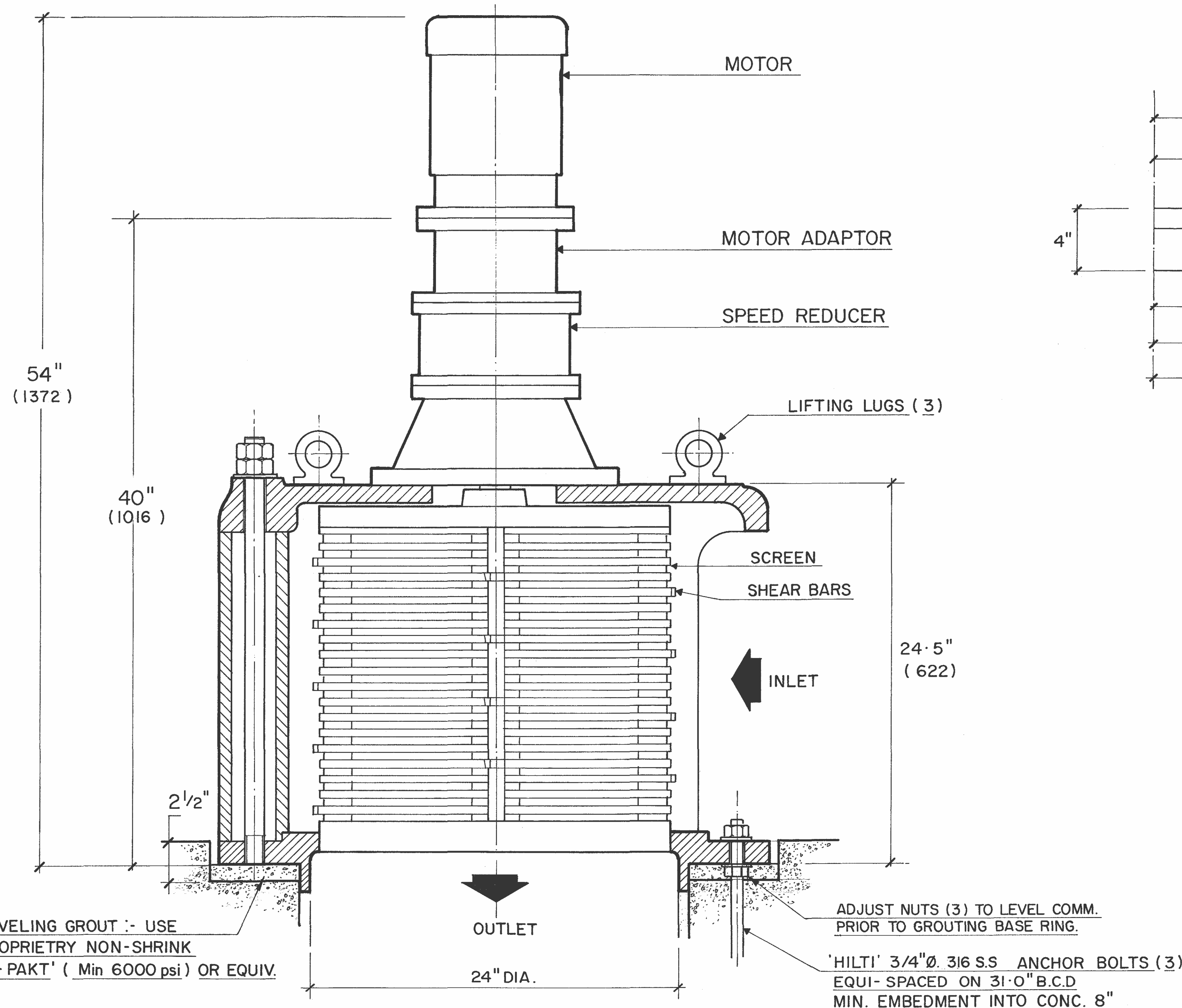
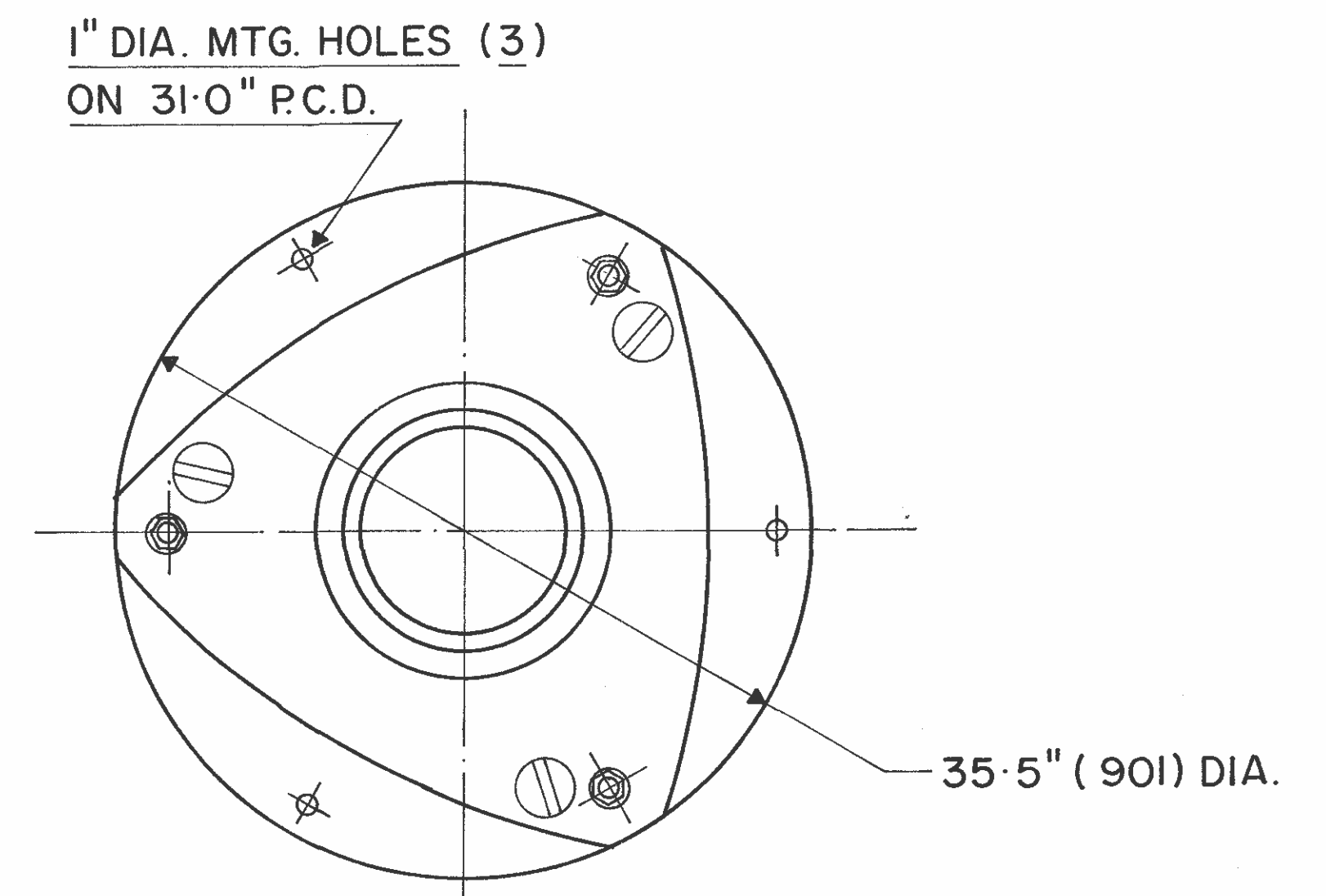

TOP VIEW OF COMMUNOTOR

MATERIALS OF CONSTRUCTION & GENERAL ENGINEERING DATA

HOUSING:	GREY IRON	CAPACITY:	10 MGD (US)/37800 m ³ /day	INLET AREA:	526 sq in 3393 cm sq
DRUM (SCREEN):	DUCTILE IRON (ASTM 536 GRADE 60-45-18)	DRUM SPEED:	30 RPM	OUTLET AREA:	324 sq in 2090 cm sq
SHEAR BARS:	AISI-A2 HIGH ALLOY TOOL STEEL	ROTATION:	CLOCKWISE	DRUM DIAMETER:	22.5 in 572 cm
CUTTING BARS:	AISI-01 TOOL STEEL REVERSIBLE	SLOT WIDTH:	0.470 in / 12 mm	WEIGHT:	1265 lb 574 kg
HARDWARE & FASTENERS:	304 STAINLESS STEEL	NO OF SLOTS:	76		
MOTOR MANUFACTURER:		POWER:	/ /	RPM:	1750
STYLE: TEFC (IP55)	HP: 3	KW: 2.24	FRAME: 182TC	FLANGE: 'C'	RATING: 11.1 HP
				SM-CYCLO REDUCER MODEL: V6170	
				RATIO: 59.1	

REVISIONS	BY	DATE	APP.
 G.E.T. INDUSTRIES INC. (877) 213-7418 www.grindhog.com			
TOLERANCES			SCALE
± DECIMAL			NTS
± FRACTIONAL			DRAWN BY
± ANGULAR			APPROVED BY
DATE	PROJECT NO.	DRAWING NO.	REV.
		6 0260	

Grind Hog MODEL 24A (CAPACITY: 10 USMGD)

REPLACEMENT OF JONES & ATTWOOD MODEL 25R

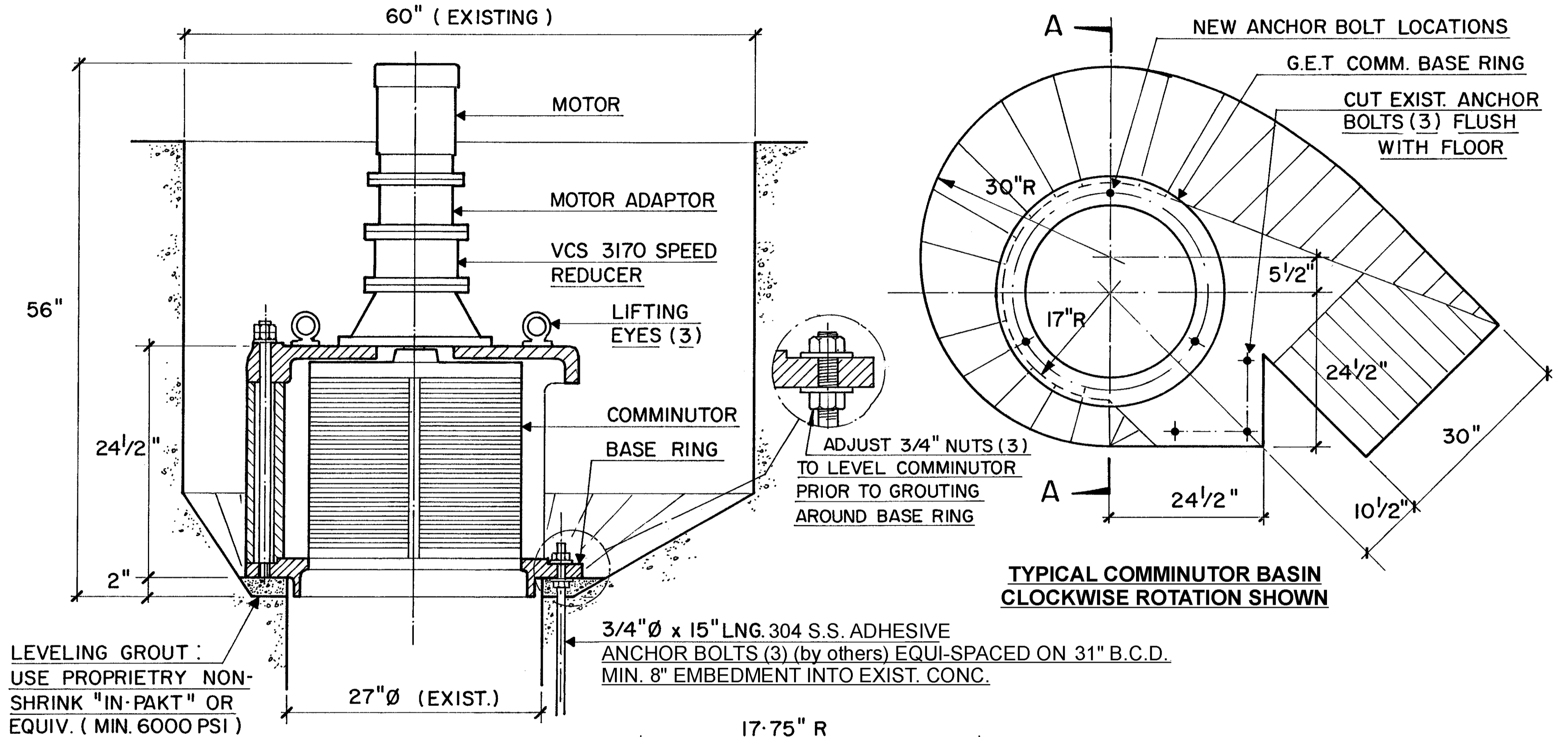

SECTION A-A

COMMINUTOR WEIGHT :
1265 LB (574 KG)

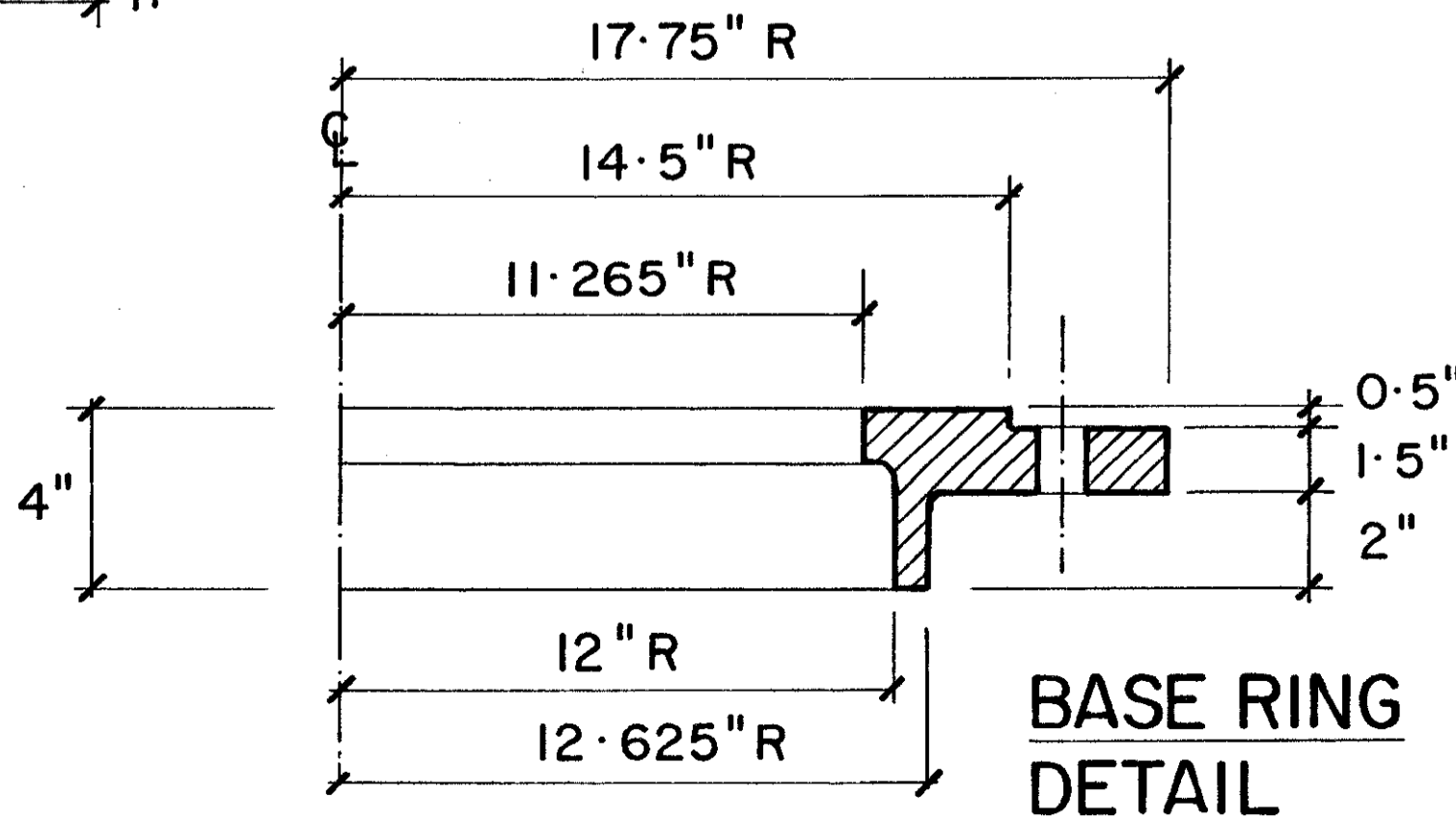

REVISIONS		BY	DATE	APP.
		G.E.T. INDUSTRIES INC. (877) 213-7418 www.grindhog.com		
TOLERANCES				SCALE
±				
DECIMAL				DRAWN BY
±				
FRACTIONAL				APPROVED BY
±				
ANGULAR				
±				
DATE	PROJECT NO.	DRAWING NO.	REV.	
		9 0080		



Grind HogTM

MODEL 24ASX

**5 Mile Pump Station
Harborcreek Township Sewer Authority
Erie County, PA**

**Replacing
Smith & Loveless
25RM**



Harborcreek Township

in Erie County, PA

GRIND HOG™ CONTROL PANEL
Installed with 25'
Power Control Cable

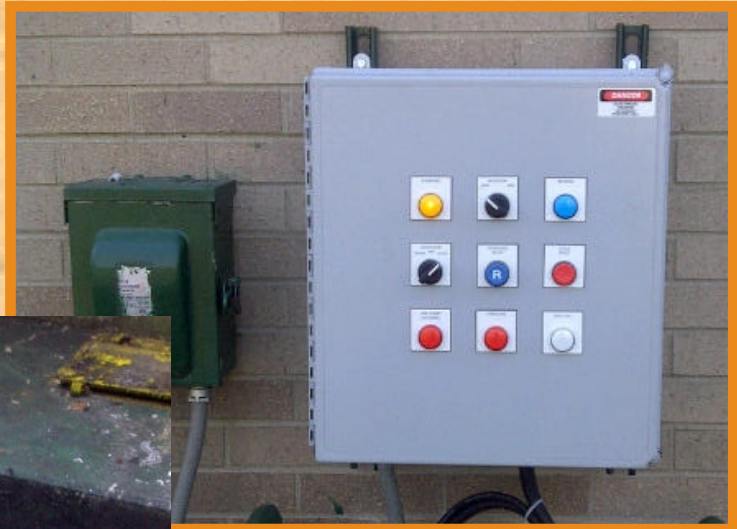

GRIND HOG™ 24ASX
Replaced Existing
Smith & Loveless 25RM



G.E.T. INDUSTRIES INC.

Toll Free: (877) 213-7418
E-mail: get@grindhog.com ♦ Web: www.grindhog.com



Grind HogTM

Town of the Blue Mountains
Craigleith Sewage
Treatment Plant Extension
2002



PREVIOUSLY INSTALLED
JONES & ATTWOOD
25RM

GRIND HOGTM 24A

CONTRACTOR

Maple Engineering &
Construction Ltd.
Brampton, ON

ENGINEER

C.C. Tatham & Associates Ltd.
Collingwood, ON



GRIND HOGTM 24A
INSTALLED

G.E.T. INDUSTRIES INC.

Toll Free: (877) 213-7418
E-mail: get@grindhog.com ♦ Web: www.grindhog.com